

Pierce Oscillator

Design and Crystal Recommendations MSP430x1xx & x3xx Families Texas Instruments

MSP430x1xx & x3xx Families

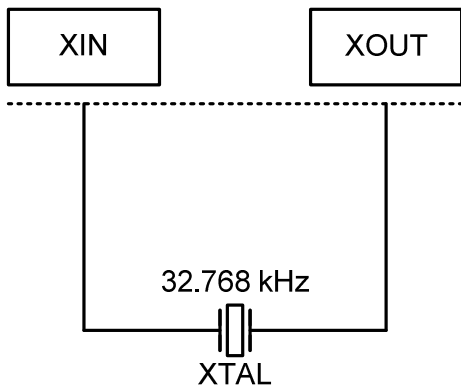

MSP430x1xx & x3xx Families

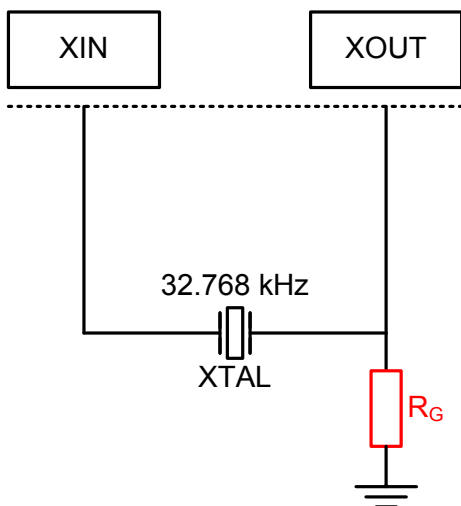

Oscillator Design Check

Test Conditions		
Power Supply Voltage V_{DD}	≥ 3.0	V
Load Capacitors	Integrated	pF
Results		
Effective Load Capacitance	10.2	pF
Oscillation Allowance	300	k Ω
Oscillator Output Voltage AC	400	mV _{RMS}
Drive Level	0.220	μ W
Startup Time	1000	ms
Overtone Mode Suppression	Safe	----

Oscillator Design Check

Test Conditions		
Power Supply Voltage V_{DD}	<3.0	V
Load Capacitors	Integrated	pF
R_G	5.1	MΩ
Results		
Effective Load Capacitance	10.2	pF
Oscillation Allowance	300	k Ω
Oscillator Output Voltage AC	350	mV _{RMS}
Drive Level	0.220	μ W
Startup Time	1000	ms
Overtone Mode Suppression	Safe	----

Recommendation

Crystal		
Crystal Type	MS3V-T1R / CC7V-T1A	
Frequency	32.768	kHz
Load Capacitance C_L	9.0 or 12.5	pF
Tolerance	+/-20	ppm

Remarks

If $V_{DD} < 3.0$ V, the 5.1 M Ω (R_G) option allows the use of SMD quartz crystals with an ESR up to 60 k Ω typ.

Please find detailed information about MS3V-T1R, CC7V-T1A and all others crystal types at www.microcrystal.com.

In accordance with our policy of continuous development and improvement, Micro Crystal reserves the right to modify specifications or design-recommendations without prior notice. The recommendations stated above are based on measured-results, respecting the "oscillator design rules". Micro Crystal makes no representation or warranty for information in this "Design and Crystal Recommendations".